

lamaPLC Communication: RS-422

RS-422, also known as TIA/EIA-422, is a technical standard originated by the Electronic Industries Alliance that specifies electrical characteristics of a digital signaling circuit. It was meant to be the foundation of a suite of standards that would replace the older RS-232C standard with standards that offered much higher speed, better immunity from noise, and longer cable lengths. RS-422 systems can transmit data at rates as high as 10 Mbit/s, or may be sent on cables as long as 1,200 meters (3,900 ft) at lower rates. It is closely related to RS-423, which uses the same signaling systems but on a different wiring arrangement.

RS-422 specifies differential signaling, with every data line paired with a dedicated return line. It is the voltage difference between these two lines that define the mark and space, rather than, as in RS-232, the difference in voltage between a data line and a local ground. As the ground voltage can differ at either end of the cable, this required RS-232 to use signals with voltage magnitudes greater than 5 volts. Moving to dedicated return lines and always defining ground in reference to the sender allows RS-422 to use 0.4 V, allowing it to run at much higher speeds. RS-423 differs primarily in that it has a single return pin instead of one for each data pin.

Comparison of RS-232, RS-422, RS-485

	RS-232	RS-423	RS-422	RS-485
Operating mode	asynchronous transmission	asynchronous transmission	synchronous transmission	synchronous transmission
Number of drives and receivers per line	1 drive 1 receiver (point-to-point)	1 drive 10 receivers (point-to-point)	1 drive 10 receivers (point-to-point)	32 stations per segment
Data transfer method	half-duplex, full-duplex	half-duplex	half duplex	half duplex
Data transmission	p2p	multi-drop (broadcast)	multi-drop (broadcast)	multipoint
Max. cable length	15 m	1200 m	1200 m	1200 m
Max. data transfer				
12 m	20 kbps	100 kbps	10 Mbps	35 Mbps
1200 m	(1 kbps)	1 kbps	100 kbps	100 kbps
Max. slew rate	30 V/ μ s	adjustable	n.a.	n.a.
Receiver input resistance	3..7 k Ω	\geq 4 k Ω	\geq 4 k Ω	\geq 12 k Ω
Drive Load-Impedance	3..7 k Ω	\geq 450 Ω	100 Ω	54 Ω
Receiver "dead band"	\pm 3 V	\pm 200 mV	\pm 200 mV	\pm 200 mV
Receiver voltage level	\pm 15 V	\pm 12 V	\pm 10 V	-7..12 V
Drive output voltage max.	\pm 25 V	\pm 14 V	\pm 12 V	-9..14 V

	RS-232	RS-423	RS-422	RS-485
Drive output voltage min. (with load)	±5 V	±3.6 V	±2.0 V	±1.5 V
Drive output short circuit current limit	500 mA to Vdc or Ground	150 mA to Ground	150 mA to Ground	150 mA to Ground 250 mA to Vdc
Receiver Hysteresis	1.15 V	50 mV	50 mV	50 mV

RS-422 signal levels

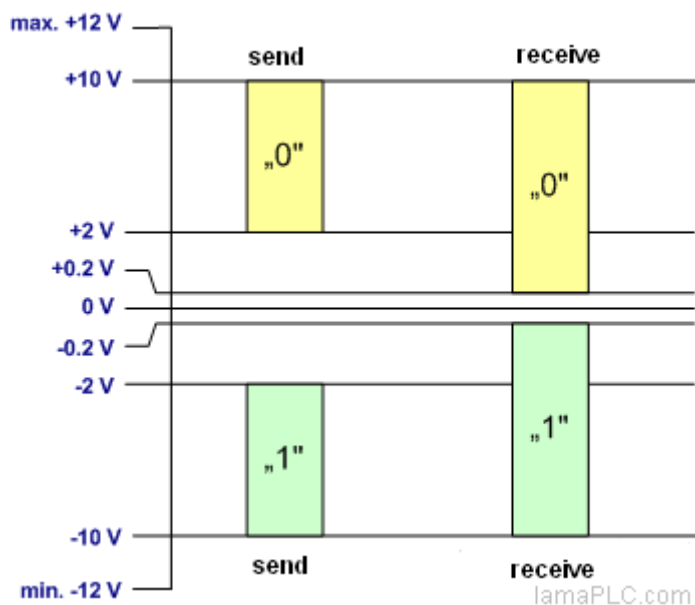

Technology of RS-422

The RS-422 transmitter produces a voltage of +/-10V as an output signal on each of its outputs. The receiver unit recognizes and accepts a +/-200 mV signal as a valid signal.

In the RS-422 system, the driver is always in the enabled state, while in the RS-485 system, the driver has three states.

The RS-422 network cannot be used in true multidrop mode, because in true multidrop mode there are several transmitters and receivers on the same line, and each participant can send and receive data at the same time.

However, it is possible to create a "quasi-four-wire multidrop" network, which is mostly used in half-duplex mode. In this case, a master sends commands to one or more slaves. RS-422 multi-participant systems are also called "broadcast" mode.

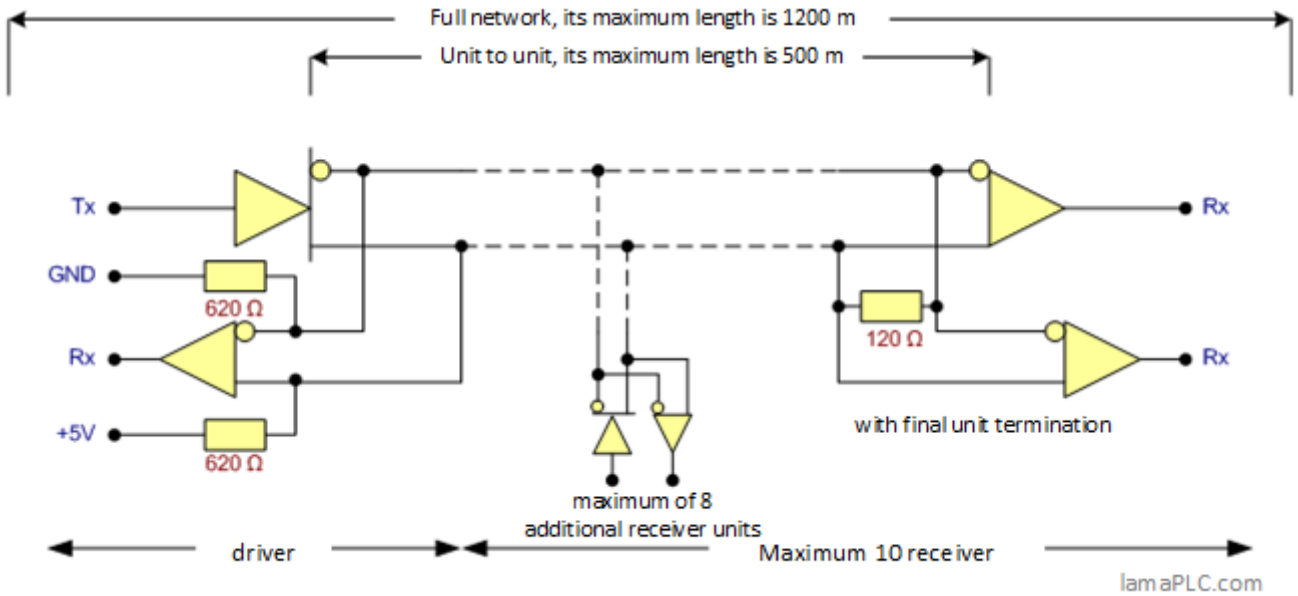

Signal rate of RSs

The transmission rate / distance ratio depends significantly on the quality of the used wire and the number of line amplifiers (repeaters). The curves below show typical values only.

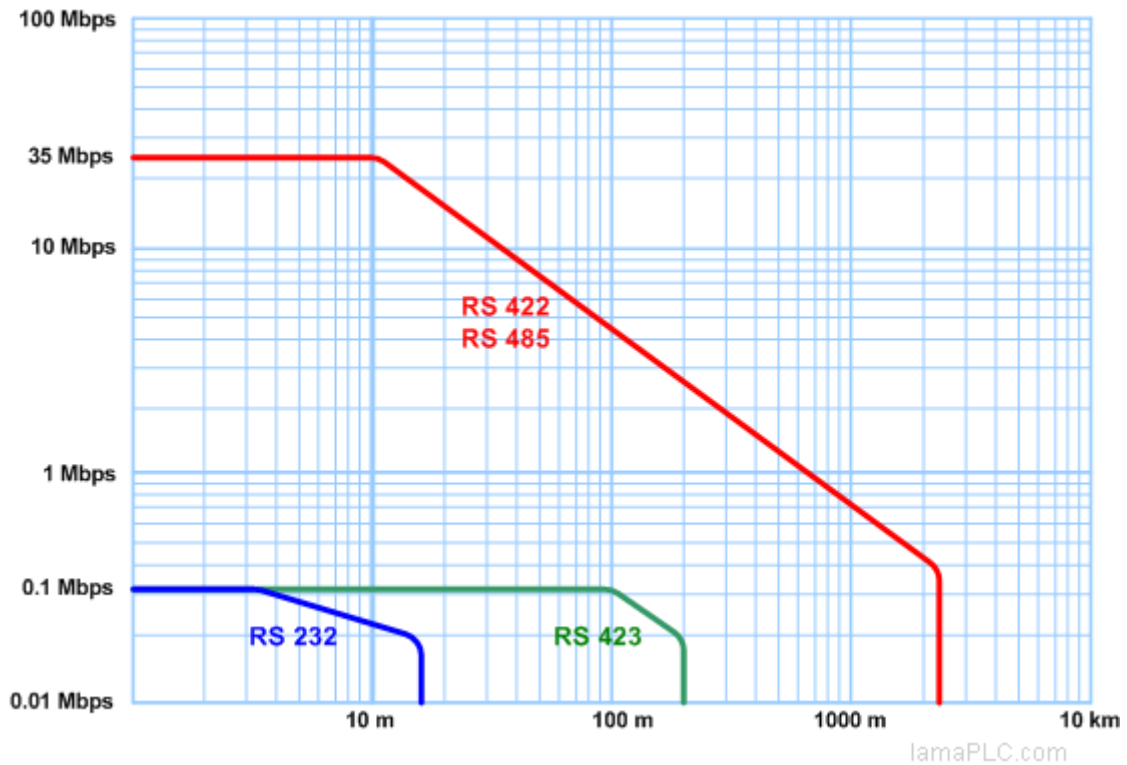

RS-422 full duplex connection

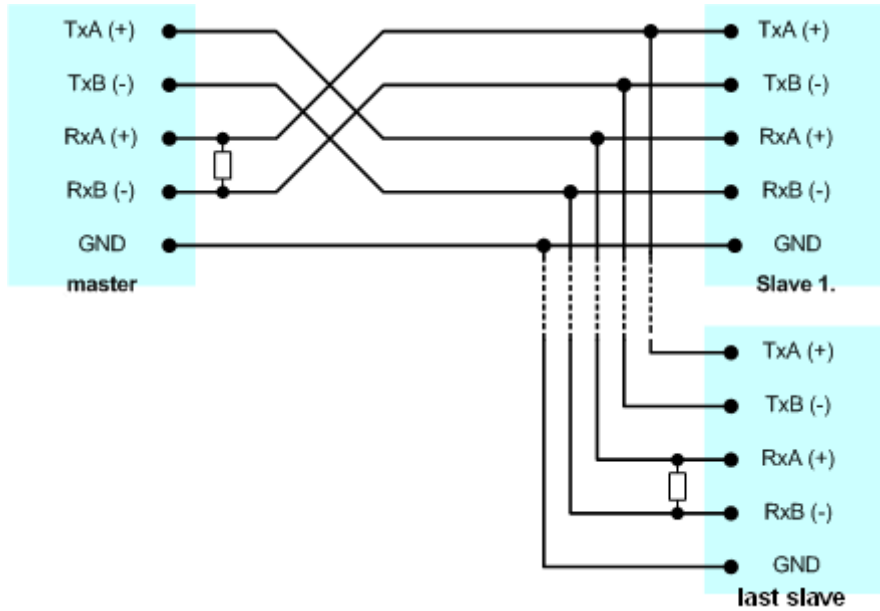

Sources

Wikipedia ([here](#))

RS-422 topics on lamaPLC

Page	Date	Tags
<ul style="list-style-type: none"> • lamaPLC Communication: RS-422 	2026/04/23 21:51	bus, communication, rs-422, rs, basic
<ul style="list-style-type: none"> • lamaPLC Communication: UART / USART basic 	2026/04/23 21:51	bus, communication, uart, rs-232, rs-422, rs-485

bus, communication, rs-422, rs, basic

This page has been accessed for: Today: 2, Until now: 4

From: <https://www.lamaplc.de/> - lamaPLC

Permanent link: https://www.lamaplc.de/doku.php?id=com:basic_rs422

Last update: **2026/04/21 20:46**

