

lamaPLC : Arduino wiring

HI active switch connection

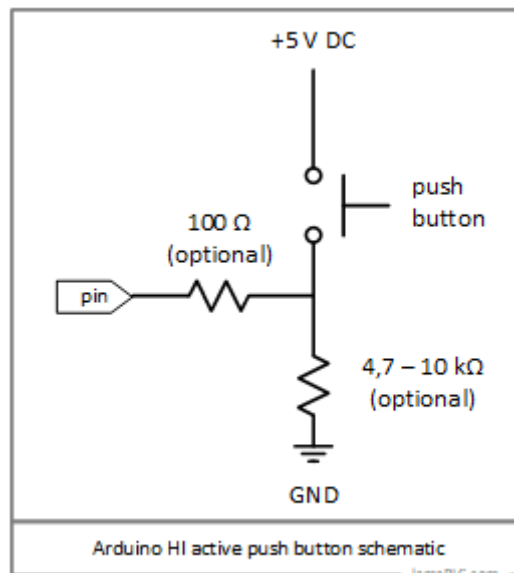

The image above shows a HI active switch connection. In the open, resting state of the circuit, the Arduino is connected to ground through a 10 kΩ (pull-down) resistor, so it is in the LO state. By pressing the button, the power supply is connected to it (it is recommended to connect a 100Ω resistor) to the input, so it goes into the HI state.

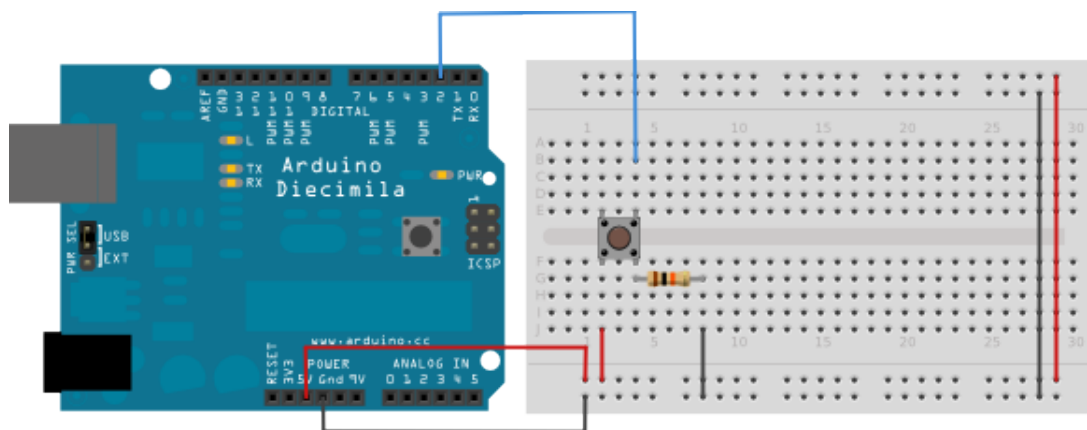

Mosfet driver

This Power Mosfet driver use two MOSFETs in parallel and can handle currents up to 15A - 400W (25A with cooling). This module is perfect for driving DC motors, DC pumps and using a PWM signal the speed can be controlled.

- Supply Voltage: 5V .. 36V
- Max current: 15A
- Working temperature:-40 .. 85°C
- PWM: 0 .. 20 kHz

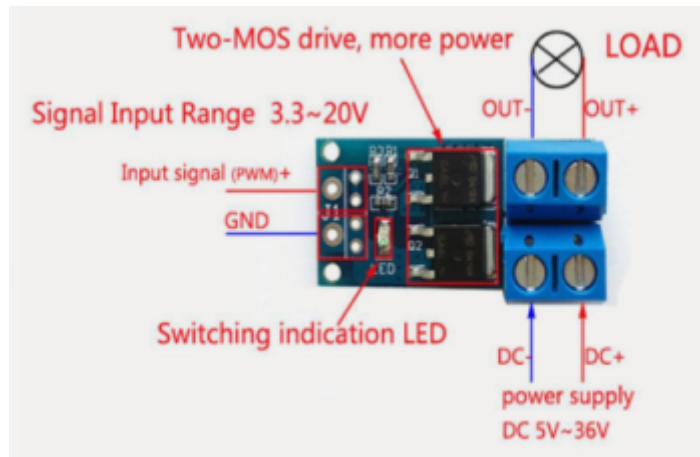

Example code

```
// Arduino Power Mosfet Driver with Two Parallel MOSFETs

#include <Arduino.h>

// Pins
const int pwmPin = 9; // PWM signal to the gate driver IC

void setup() {
  // Set up pins
  pinMode(pwmPin, OUTPUT);
}

void loop() {
  // Adjust the duty cycle to control the power output
  int dutyCycle = map(analogRead(A0), 0, 1023, 0, 255);

  // Write the duty cycle to the PWM pin
  analogWrite(pwmPin, dutyCycle);

  // Optional: Add a delay to control the update rate
  delay(20);
}
```

From:

<https://www.lamaplc.de/> - **lamaPLC**

Permanent link:

<https://www.lamaplc.de/doku.php?id=arduino:wiring>

Last update: **2026/04/21 20:48**

